

LASER4DIY Low Profile XY Table

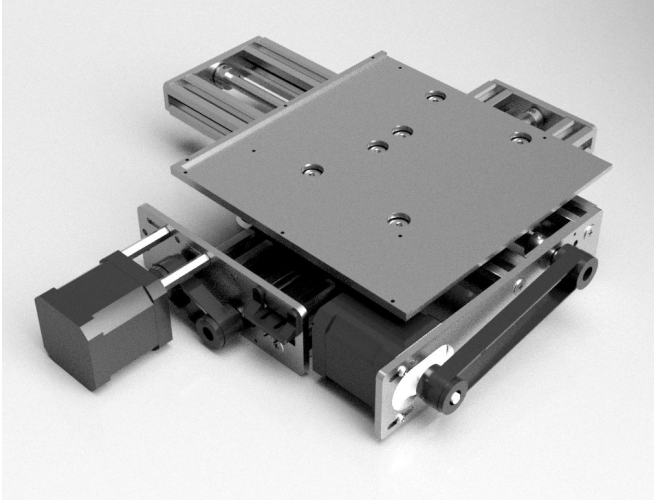

- Table Size: 165mm x 165mm
- Overall Size: 368mm x 333mm x 56mm (with pancake motor)
- Based on 2 [OpenBuilds NEMA17 V-Slot Actuators with Lead Screw](#)

Files

See <https://github.com/Laser4DIY/XY-Table>

License

The Laser4DIY XY Table is licensed under the CERN-OHL-P v2.

Parts List

Off-the-shelf parts

Qty	Part Name	Part Link	Comments
2	8mm Metric Acme Lead Screw 290mm	openbuildspartstore.com makersupplies.dk ratrig.com	
2	Anti-Backlash Nut Block for 8mm Metric Acme Lead Screw	openbuildspartstore.com makersupplies.dk ratrig.com	SKU 1055; set includes M5 lock nuts
4	V-Slot 20x20mm 250mm	makersupplies.dk ratrig.com	
8	Xtreme Solid V Wheel Kit	openbuildspartstore.com makersupplies.dk ratrig.com	SKU 465
4	Aluminum Spacers - 6mm	openbuildspartstore.com ratrig.com	SKU 90
4	Eccentric Spacer - 6mm	openbuildspartstore.com ratrig.com	SKU 226
4	Ball Bearing 688Z 8x16x5	openbuildspartstore.com ratrig.com	SKU 780
4	8mm Shim (12x8x1mm)	openbuildspartstore.com ratrig.com	SKU 835
4	Lock Collar - 8mm	openbuildspartstore.com ratrig.com	SKU 840
5	V-Slot T-Nut M5	openbuildspartstore.com ratrig.com	
4	M5 x 20mm Low Profile Screw	openbuildspartstore.com ratrig.com ratrig.com(25pack)	SKU 750-pack
8	M5 x 22mm Low Profile Screw	aliexpress.com	for mounting wheels
8	M5 Nut Low Profile	openbuildspartstore.com ratrig.com	SKU 181; for mounting wheels
11	M3 x 8mm Button Head Screw		
4	M3 x 5mm Button Head Screw		For screwing SledPlate to BedPlate
10	M3 Nut		
6	M2 x 6mm Screw		

4	M2 x 10mm Screw		
10	M2 Nut		
2	M2 Washer		
8	Self Tapping Screw #10	openbuildspartstore.com ratrig.com	SKU 720
3	Hex Standoff M3 (female/male) 30mm		For mounting one of the stepper motors
2	NEMA 17 Stepper Motor	openbuildspartstore.com ratrig.com	Use pancake motor to save space
2	GT2 pulley 20 5mm bore	makersupplies.dk ratrig.com	
2	GT2 pulley 20 8mm bore	makersupplies.dk	
1	GT2 timing belt 6 mm closed loop 128 mm	gtech-shop.de	
1	GT2 timing belt 6 mm closed loop 250 mm	gtech-shop.de	
2	Micro Switch		Panasonic AV32143AT or similar

Custom parts

Qty	Part Name	Process	Material	File	
2	StandardEndPlate_BeamBracket	Laser cutting	Aluminium (AlMg3), 2mm	2mm_ALL_with_tabs.dxf	
2	StandardEndPlate_InnerPart	Laser cutting	Aluminium (AlMg3), 2mm	- " -	
2	StandardEndPlate_OuterPart	Laser cutting	Aluminium (AlMg3), 2mm	- " -	
1	EndPlateLower_BeamBracket	Laser cutting	Aluminium (AlMg3), 2mm	- " -	
1	EndPlateLower_InnerPart	Laser cutting	Aluminium (AlMg3), 2mm	- " -	
1	EndPlateLower_OuterPart	Laser cutting	Aluminium (AlMg3), 2mm	- " -	
1	EndPlateUpper_BeamBracket	Laser cutting	Aluminium (AlMg3), 2mm	- " -	
1	EndPlateUpper_InnerPart	Laser cutting	Aluminium (AlMg3), 2mm	- " -	
1	EndPlateUpper_OuterPart	Laser cutting	Aluminium (AlMg3), 2mm	- " -	
1	BedRuler	Laser cutting	Aluminium (AlMg3), 2mm	- " -	
2	SledPlate	Laser cutting	Aluminium (AlMg3), 3mm	3mm_ALL_with_tabs.dxf	
1	BedPlate	Laser cutting	Aluminium (AlMg3), 3mm	- " -	
2	SledSpacer	Laser cutting	MDF, 5mm	5mm_sledspacer.dxf	Could also be aluminium
1	Microswitch Bracket	3d printing	any plastic e.g. PLA	MicroswitchBracket.stl	
1	Microswitch Bracket 2	3d printing	any plastic e.g. PLA	MicroswitchBracket.2stl	

The "end plates" are made of 3 layers of lasercut aluminium, which are aligned and held together by M3 screws. It is also possible to have them CNC milled as one piece, but we chose laser cutting as it is much cheaper to get them produced this way.

Overall Size

The overall size of the table is larger than its components, as the table moves beyond their extents. The following drawing shows how much space is needed. The aluminum extrusions of the lower rail (vertical in the drawing) are the ones that should be fixed e.g. to a mounting plate using brackets or V-slot T-nuts.

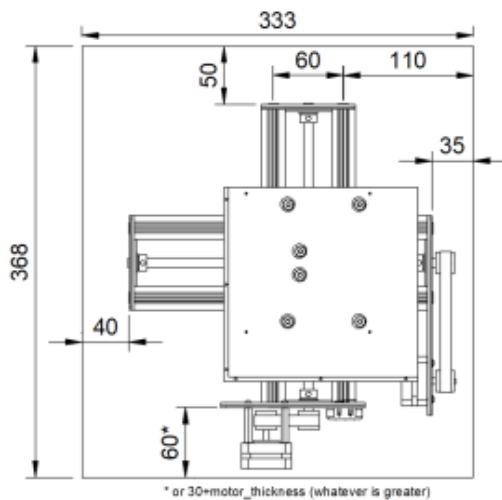

Assembly

- Please see included STEP file where the individual parts go.
- The wheels are attached with 6mm spacers, with standard spacers on one side and eccentric spacers on the other side of the sled. The eccentric spacers can be used to increase the force the wheels press onto the beams.
- The lasercut holes in the aluminium plates are often too small. Drill them out to have the right sizes so that the screws go through. The only exception are 4 holes in the bed plate:

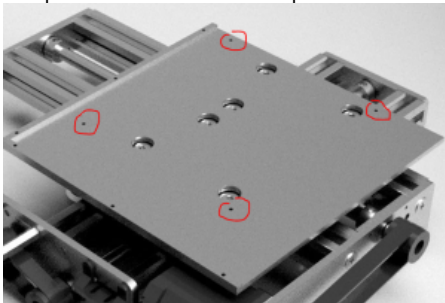

These holes need an M3 thread to be cut into. Use M3x5 screws to bolt the upper sled plate to the bed plate using these threaded holes.

- The 8mm shims (12x8x1mm) are not shown in the STEP file. The shims go onto the lead screws between the lock collars and the ball bearings.

Copyright FabLab München e.V. 2021

This source describes Open Hardware and is licensed under the CERN-OHL-P v2

You may redistribute and modify this documentation and make products using it under the terms of the CERN-OHL-P v2 (<https://cern.ch/cern-ohl>). This documentation is distributed WITHOUT ANY EXPRESS OR IMPLIED WARRANTY, INCLUDING OF MERCHANTABILITY, SATISFACTORY QUALITY AND FITNESS FOR A PARTICULAR PURPOSE. Please see the CERN-OHL-P v2 for applicable conditions